

Available
Technologies

Combined Quantitative Phase-Contrast and Epi-Fluorescence Microscope

Applications:

- Quantitative brightfield/phase contrast and epi-fluorescence biological microscope
- Imaging of live cells
- Measuring internal structures of a specimen
- Dynamic process monitoring such as:
 - drug delivery
 - disease progression
 - general pathology

Advantages:

- Non-invasive, real-time study of specimen physical structure/refractive index
- Fast image acquisition
- Reduced errors due to elimination of phase unwrapping algorithms
- Enables identification of individual cell structures
- Enables analysis of relationship between cellular morphology and functionality

Contact:

Mark Reeves

Oak Ridge National Laboratory
P.O. Box 2008, Mail Stop 6196
Oak Ridge, TN 37831
(865)576.2577

reevesme@ornl.gov

www.ornl.gov/adm/partnerships/

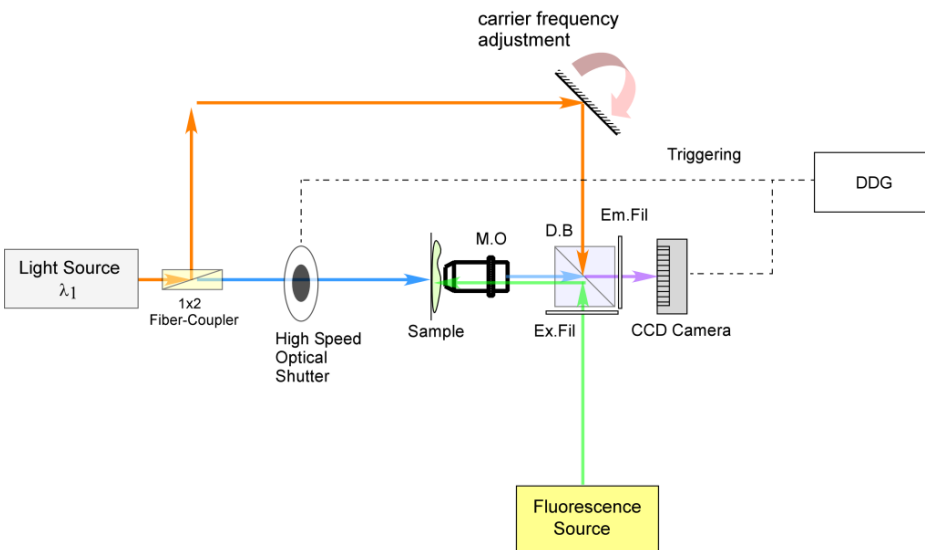

Single-wavelength digital holography in combination with epi-fluorescence microscopy.

Summary:

Technology Description

A means to study living samples simultaneously with two different yet complimentary microscopic techniques. The invention enables the deterministic and real-time study of specimen physical structure/refractive index, as well as the specificity to identify individual structures. This presents a way of analyzing the relationship between cellular morphology and functionality and can be used to monitor dynamic processes such as drug delivery and progression of diseases.

Technology Application

Quantitative brightfield/phase contrast and epi-fluorescence biological microscope

Stage of Development: Proof of Principle

Patent Status: Patent application in progress

Licensing Status: Available for licensing in specific fields of use